

# Agilent PSA Series Spectrum Analyzers



# Performance Exceeding Expectations

The brainpower and the will are already yours; the next step is selecting precisely the right tools to reach the market first.

In 1964, Hewlett-Packard Company introduced its first spectrum analyzer at the birth of the technology revolution. Since that time, HP and now Agilent Technologies have continued to be industry leaders in spectrum analysis tools. Today, Agilent offers an entirely new platform for high-performance spectrum analysis.

The Agilent PSA Series offers high-performance spectrum analysis up to 50 GHz with powerful one-button measurements, a versatile feature set, and a leading-edge combination of flexibility, speed, accuracy, and dynamic range. From millimeter wave and phase noise measurements to spur searches and modulation analysis, the PSA Series offers unique and comprehensive high-performance solutions to R&D and manufacturing engineers in cellular and emerging wireless communications, aerospace, and defense.



## Dynamic range

Fine-tune measurements with the industry's most usable dynamic range.



## Accuracy

Design with confidence in guaranteed accuracy.



## Flexibility

Take control of measurement setups through advanced flexibility.



## Speed

Increase throughput and design efficiently with fast measurements.

PSA Series frequency range summary

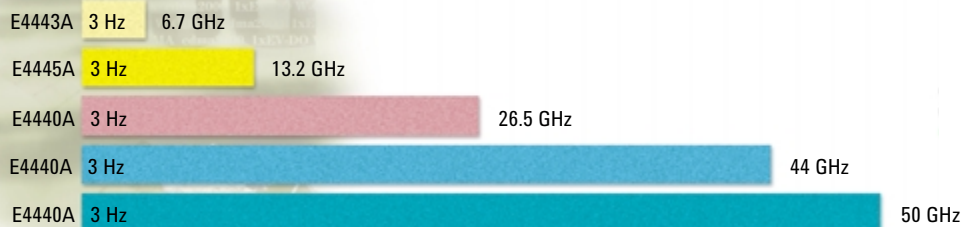

# Capability Beyond Limitation

## Power Suite

Make an assortment of challenging power measurements easily with this standard toolset. It offers the most complete one-button advanced power measurements with wireless format-based setups.

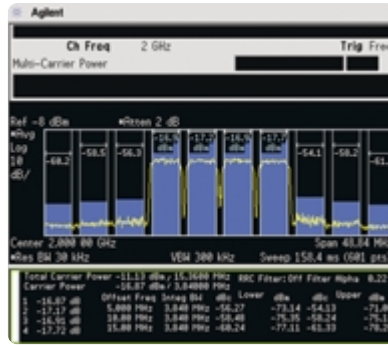

W-CDMA multi-carrier power measurement

The PSA Series offers a wide variety of features for making more than just traditional spectrum analyzer measurements.

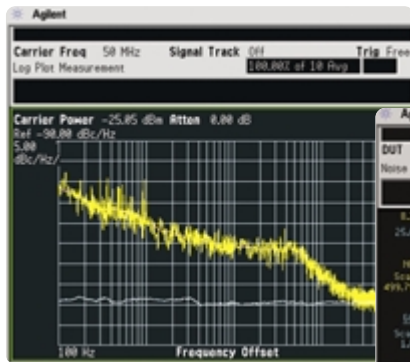

Phase noise log plot measurement

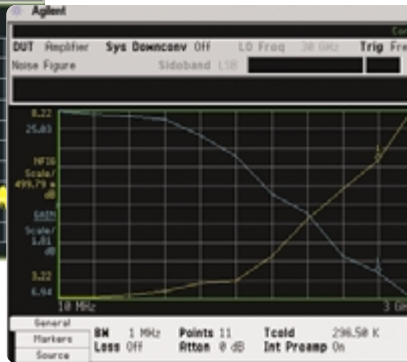

Noise figure and gain measurement

## Phase noise and noise figure measurement personalities

Take advantage of the PSA Series' outstanding performance and ease of use to make phase noise and noise figure measurements. Conveniently built in to the analyzer, these optional measurement personalities provide advanced capability with one-button measurement simplicity.

## Digital modulation analysis

Decades ago, the term “wireless” was used to describe AM radio. Today it is used to describe the industry that is encircling the globe with voice and data communications devices in a variety of different modulation formats. The PSA Series offers powerful, format-based digital modulation analysis with one-button measurement setups in a growing variety of optional measurement personalities.

- W-CDMA
- GSM with EDGE
- cdma2000
- 1xEV-DO
- cdmaOne
- NADC, PDC

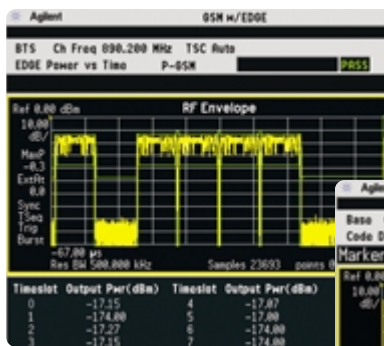

EDGE power versus time



W-CDMA code domain analysis

# High-Performance Spectrum Analysis

The PSA Series has great specifications to provide wide dynamic range.

- displayed average noise level (DANL) of -154 dBm (-169 dBm with optional preamplifier)
- third order intercept (TOI) of +17 dBm (+19 dBm typical)
- maximum third order dynamic range of 114 dB
- > 110 dB of calibrated log display range
- 1 dB compression point at +3 dBm (+7 dBm nominal)
- 4.1:1 RBW selectivity (nominal)
- excellent phase noise
  - -114 dBc/Hz at 10 kHz offset
  - -144 dBc/Hz at 1 MHz offset
  - -151 dBc/Hz at 10 MHz offset

The new PSA millimeter wave spectrum analyzers (E4446A and E4448A) provide the highest available dynamic range from 26.5 to 50 GHz for emerging communications and aerospace and defense industries.

- widest distortion free third order dynamic range: 95 dB at 44 GHz
- lowest sensitivity: -131 dBm at 44 GHz
- best wide offset phase noise: -130 dBc/Hz (1 MHz offset) at 40 GHz

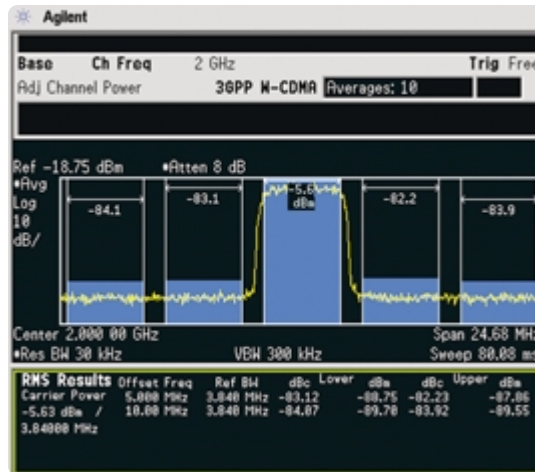

W-CDMA ACP measurement

Great specifications are just the starting point for great measurements. The PSA Series has the technology to offer unprecedented control over dynamic range, resolution, and speed.



## Dynamic range

- standard 2 dB step attenuator up to 50 GHz
- 10% resolution bandwidth (RBW) steps (160 RBW settings) from 1 Hz to 8 MHz
- digital IF and ADC with feed forward and autorange capability
  - move marker off the screen and still get accurate results
  - wide log range with accurate measurements anywhere on the display
  - negligible quantization error
  - optional preamplifier with flatness and gain calibrated into measurements

The above example shows the popular benchmark W-CDMA adjacent channel power (ACP) measurement. Achieve 81 dB (typical) dynamic range with the PSA Series using Agilent's unique noise correction algorithm.

Refer to the PSA Series product note entitled *Optimizing Dynamic Range for Distortion Measurements*, literature number 5980-3079EN, for more information on dynamic range in the PSA Series.

The PSA Series achieves unsurpassed accuracy. The specifications that make this possible are

- absolute amplitude accuracy of  $\pm 0.62$  dB up to 3 GHz ( $\pm 0.24$  dB, 95% confidence)
- most accurate amplitude measurements above 26.5 GHz:  $\pm 3.24$  dB at 44 GHz
- frequency response of  $\pm 0.38$  dB up to 3 GHz ( $\pm 0.15$  dB, typical)
- log amplification linearity of  $\pm 0.07$  dB
- 0 dB reference level uncertainty

How are these exceptional specifications achieved?

- all-digital IF section that reduces or eliminates errors in RBW uncertainty, log amplifier fidelity, RBW filter sweep effects, RBW switching uncertainty, and IF gain uncertainty
- highly accurate, built-in 50 MHz reference signal
- auto alignment algorithm guarantees accuracy with temperature changes
- fully-calibrated attenuators across frequency and amplitude

With superior linearity, the PSA Series of spectrum analyzers makes very precise relative power measurements and provides the resolution necessary to take full advantage of this capability.

For more information on measurement accuracy of the PSA Series, see the product note entitled *PSA Series Amplitude Accuracy*, literature number 5980-3080EN.

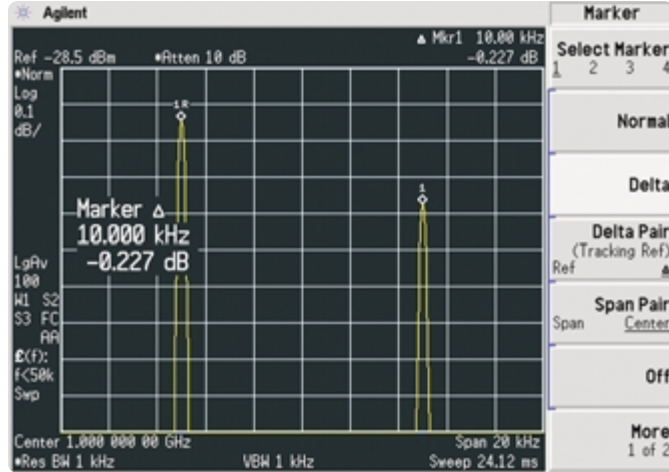

This figure illustrates 0.1 dB/division display resolution, 0.01 dB reference level resolution, and 0.001 marker resolution with averaging.

### Amplitude correction

Let the PSA help improve the accuracy of the rest of your test system adding up to four sets of amplitude correction curves versus frequency. Amplitude correction can be used to compensate for gains and losses in cables, antennas, amplifiers, etc.



# High-Performance Spectrum Analysis

Take control of measurement setups with the substantial flexibility of the PSA Series. Beside the standard 2-dB step attenuator and 160 RBW settings, there are additional features that can improve speed, dynamic range, and data representation.

## Swept mode or FFT mode

There are two ways in which the PSA Series can perform swept spectrum analysis. The more traditional swept mode measures the power level at each frequency as it is passed through the resolution bandwidth filter. Another method performs a fast Fourier transform (FFT) algorithm on digitized time data to make the measurements. The FFT mode can often reduce the sweep time for measurements with narrow spans and narrow resolution bandwidths. Having both of these methods in one analyzer assures the best possible speed.

## Phase noise optimization

The PSA Series' local oscillator (LO) phase lock loop configuration can be set to optimize phase noise close to a carrier (below 50 kHz offset), far from a carrier (above 50 kHz offset), or for speed. Optimizing close-in or far-out phase noise performance improves dynamic range.

## An array of detectors

The complex signals of today's broadband technology consist of any combination of continuous wave, noise, and modulated signals. Detector modes become important for accurately measuring these different types of signals. The PSA Series offers this complete suite of detectors to assure correct measurement results:

- normal
- average (log, rms, voltage)
- peak
- sample
- negative peak

## Auto couple

From the novice to the most knowledgeable expert, the PSA makes it easy for anyone to obtain accurate, reliable results from their measurements. Each measurement setting can be automatically determined by the PSA for optimization of speed and dynamic range. For more operator control, flexibility features are easily accessed from a single menu.



## Flexibility

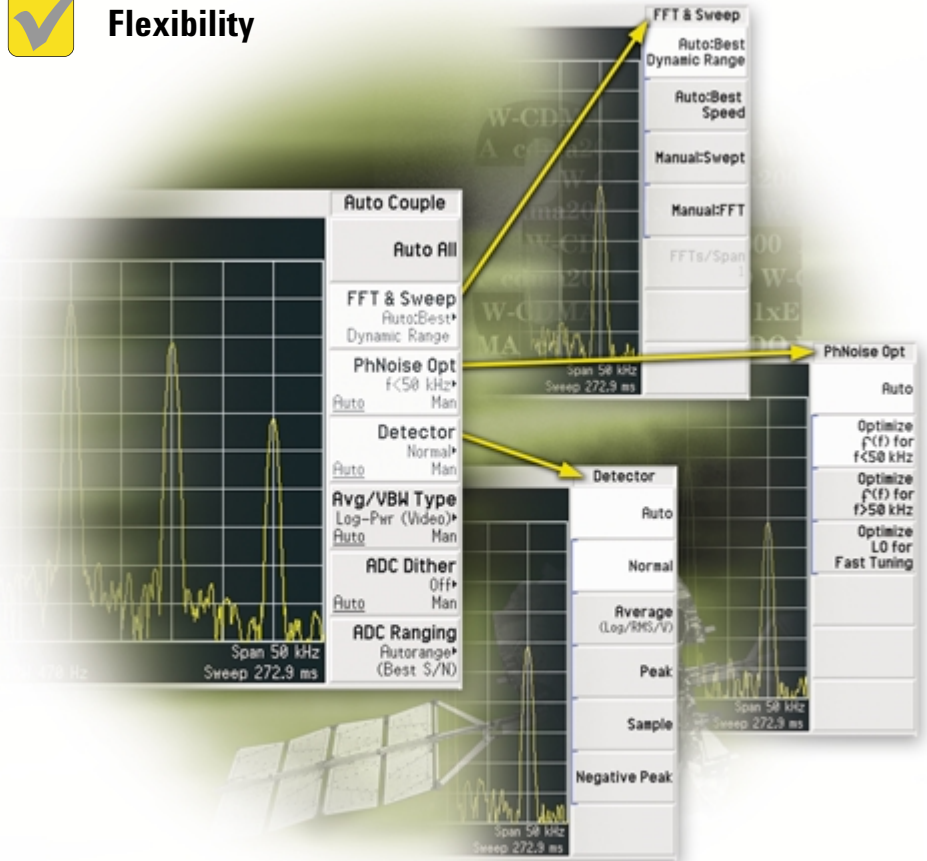

In addition to shorter measurement times in narrow spans with the FFT mode, swept measurements also have remarkable speeds. Because of the all digital IF and excellent sensitivity, the PSA Series is able to achieve

- 1-ms frequency sweep times in swept mode
- 1- $\mu$ s sweep times in zero span
- local update rate of > 50 measurements per second
- remote operation update rate of > 45 measurements per second
- incredibly fast low-level spur searches
- increased frequency resolution without increased sweep times, 101 to 8192 sweep points

 **Speed**

Traditional swept measurement

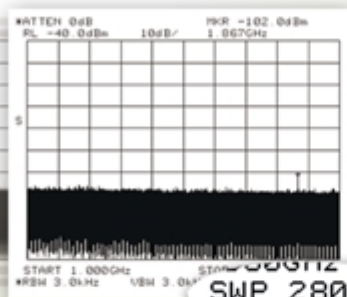

Compared to older generations of spectrum analyzers, the PSA Series makes this low-level spur search measurement over two times faster in swept mode and over 20 times faster in FFT mode.

PSA Series swept measurement

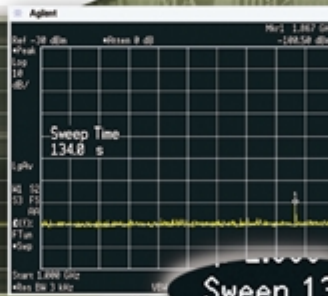

Sweep 134 s

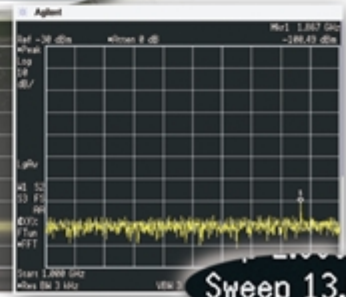

Sweep 13.4 s

PSA Series FFT algorithm measurement

# Power Suite: The Power to Realize

Making broadband signal measurements simple and intuitive requires unique spectrum analyzer measurement capability. The PSA Series offers a comprehensive suite of flexible, one-button RF and microwave power measurements with wireless format-based setups. Power Suite is a standard tool set included in every PSA Series spectrum analyzer.

## Power Suite measurements

- channel power
- occupied bandwidth
- adjacent channel power (with multiple offsets)
- multicarrier power/12-carrier ACP
- power statistics (CCDF)
- harmonic distortion
- burst power
- third order intercept (TOI)
- spurious emissions
- spectrum emission mask

## Format-based setups

- IS-95A
- J-STD-008
- IS-95C
- GSM/EDGE
- 3GPP W-CDMA
- cdma2000 MC-1X
- cdma2000 MC-3X
- cdma2000 DS
- NADC
- PDC
- *Bluetooth™*
- TETRA
- WLAN 802.11a
- WLAN 802.11b
- WLAN 802.11g
- WLAN HiperLAN/2
- DVB-T L/SECAM/NICAM
- DVB-T G/PAL/NICAM
- DVB-T I/PAL/NICAM

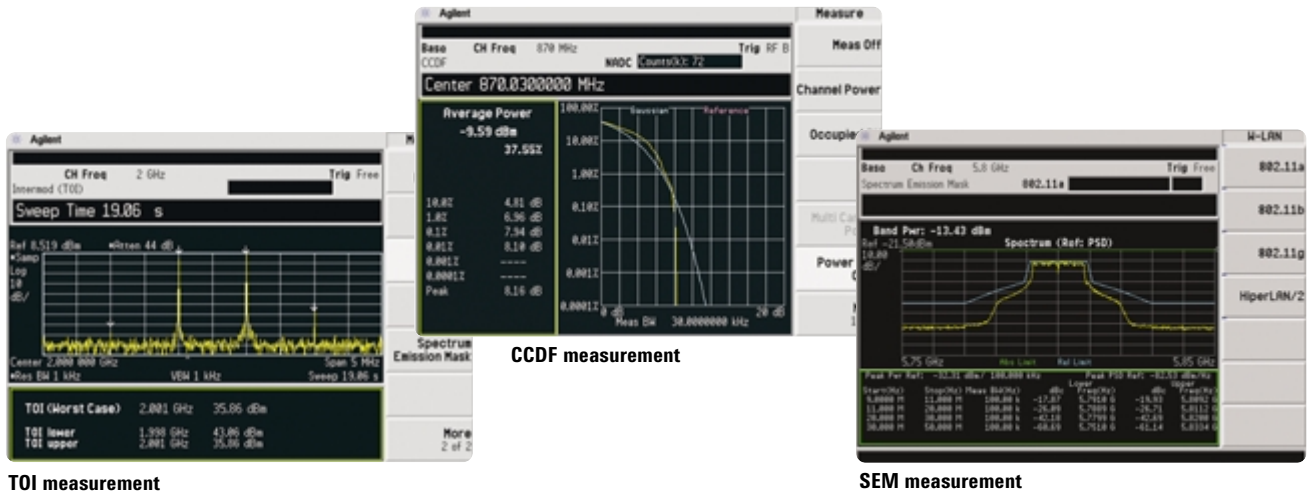



# A Spectrum Analyzer with a Digital Brain

## Agilent PSA Series block diagram

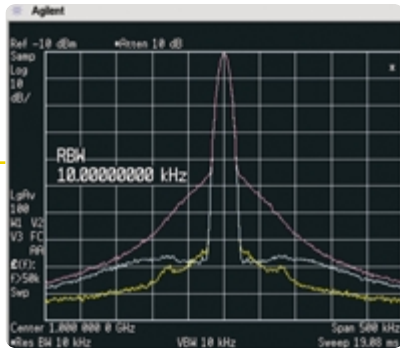
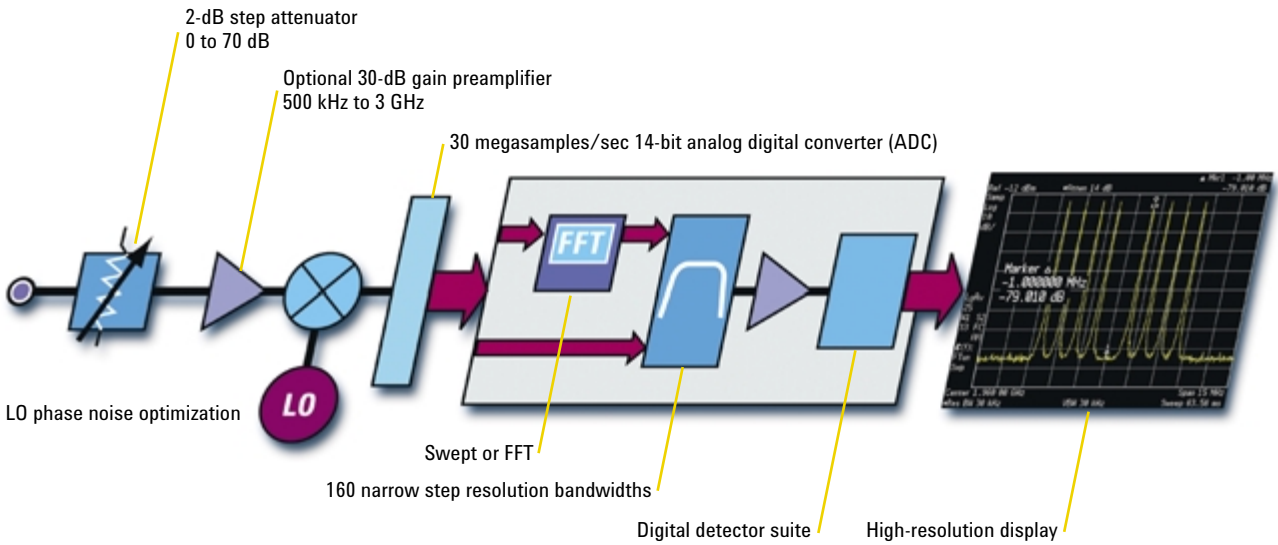

**Comparison of phase noise optimization for fast tuning, for > 50 MHz, and for < 50 MHz**

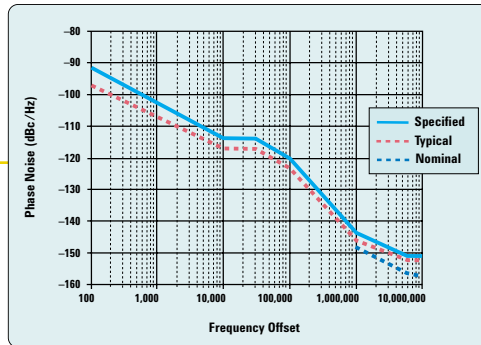

**PSA Series phase noise performance plot (1 GHz center frequency)**

The Agilent PSA Series features an all-digital implementation of a swept spectrum analyzer IF section. This innovation is responsible for faster sweep speeds, narrow steps in resolution bandwidth, high linearity in log amplification, versatile detector modes, and high display resolution. Digital signal processing (DSP) also enables the analyzer's FFT and digital demodulation capabilities.

To learn more about DSP and other technology innovations of the Agilent PSA Series, refer to our product note entitled *PSA Series Measurement Innovations and Benefits*, literature number 5980-3082EN.

## Truly User Friendly

The PSA Series has a simple and intuitive user interface. The display is large and bright with effective use of colors. Front panel hard keys perform frequently used functions and provide access to menus. Soft keys on the display are organized for quick and easy navigation. One-button set-ups are provided for many measurements.

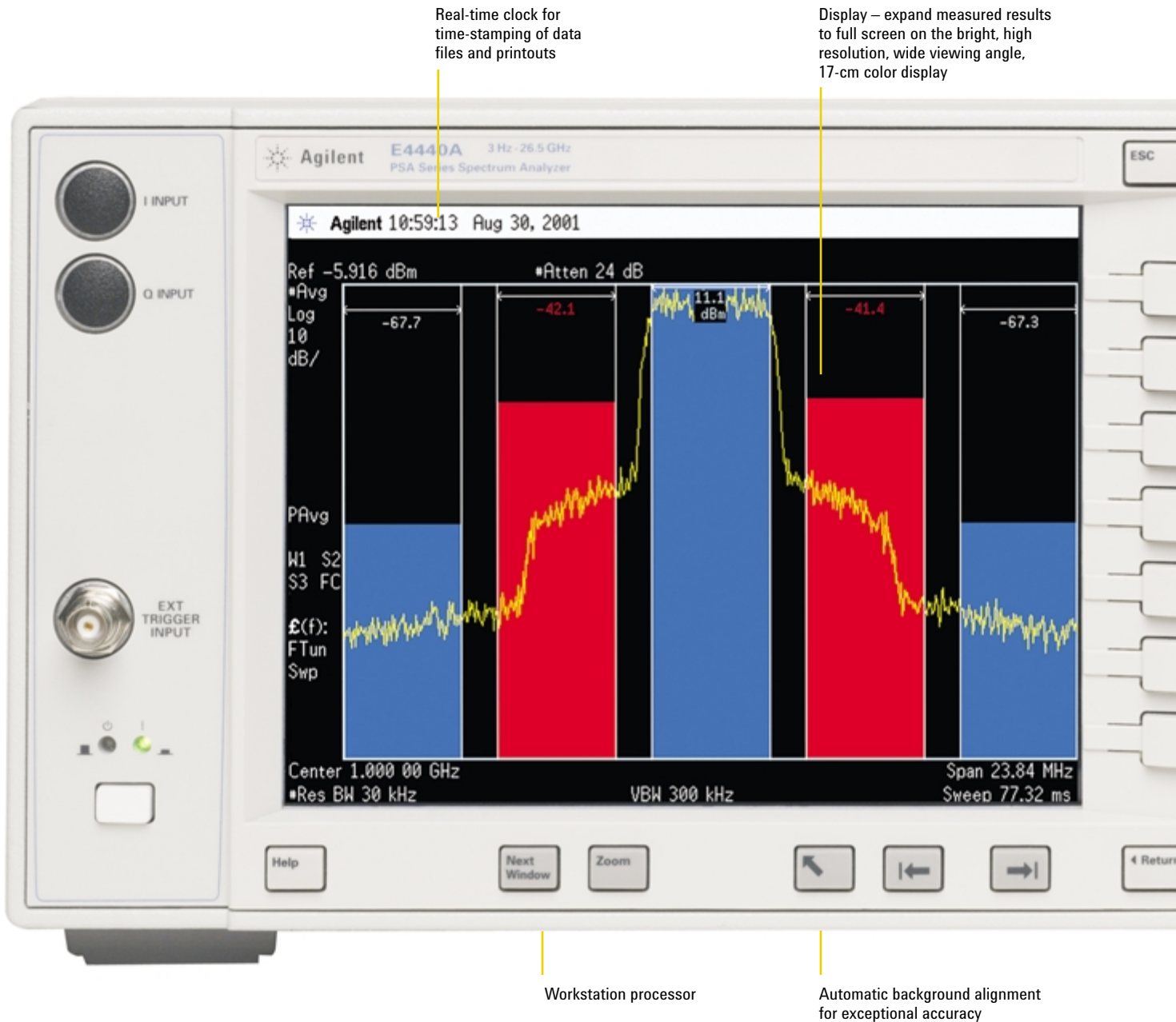

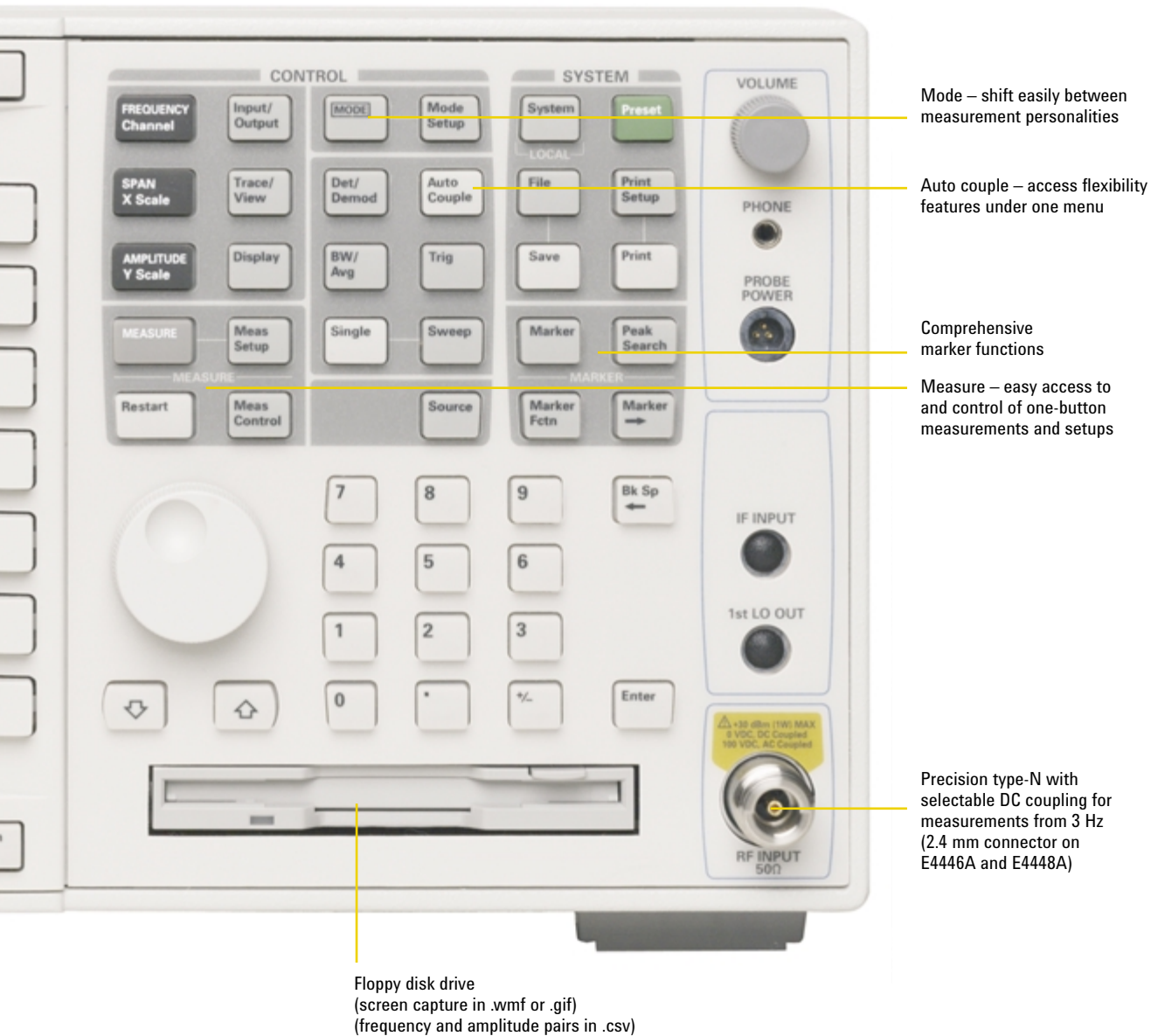
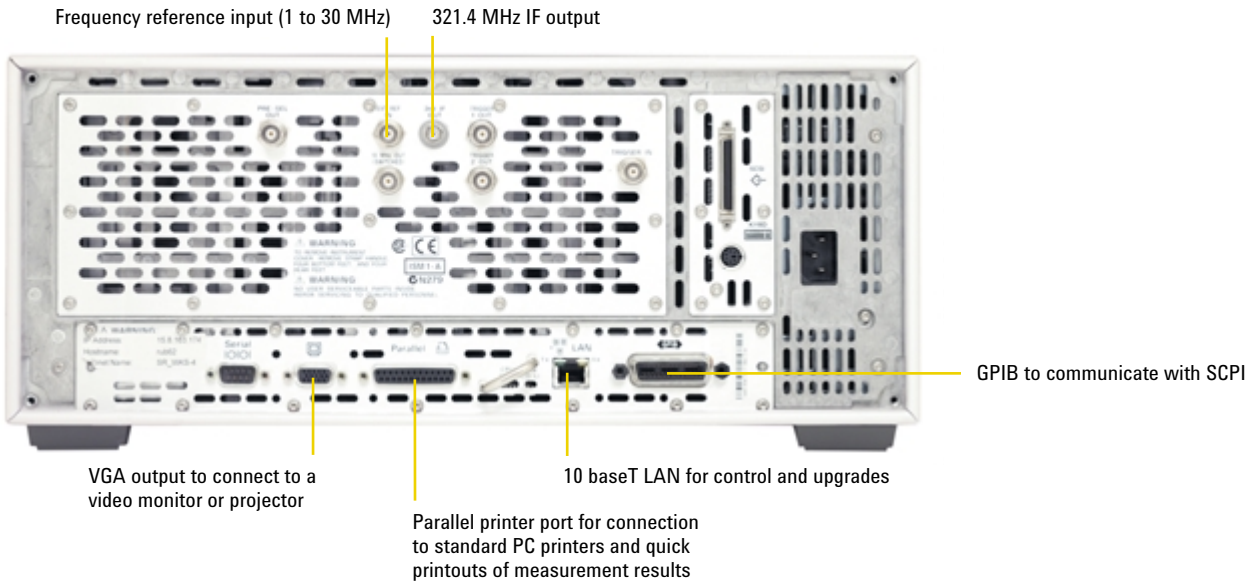

# General-Purpose Measurement Personalities

## Phase noise measurement personality (Option 226)

This optional, built-in measurement personality consolidates advanced spectrum analysis capability and phase noise measurements into a single oscillator test. This flexible tool can quickly and easily generate plots of phase noise in dBc/Hz versus log offset frequency or measure jitter or make continuous spot frequency phase noise measurements.

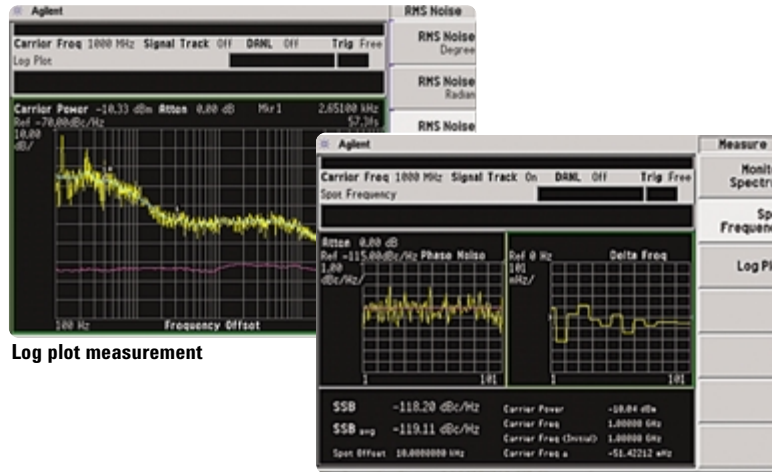

Log plot measurement

Spot frequency measurement

## Noise figure measurement personality (Option 219)

The noise figure measurement personality provides fast, one-button noise figure and gain measurements from 200 kHz up to 26.5 GHz. DUT setup menus help guide you easily through amplifier and mixer measurements, and a built-in measurement uncertainty calculator makes it easy to qualify your measurement system. An optional internal preamplifier (Option 1DS) improves instrument uncertainty to  $\pm 0.05$  dB below 3 GHz, so you can conveniently and accurately measure devices with low noise figure.

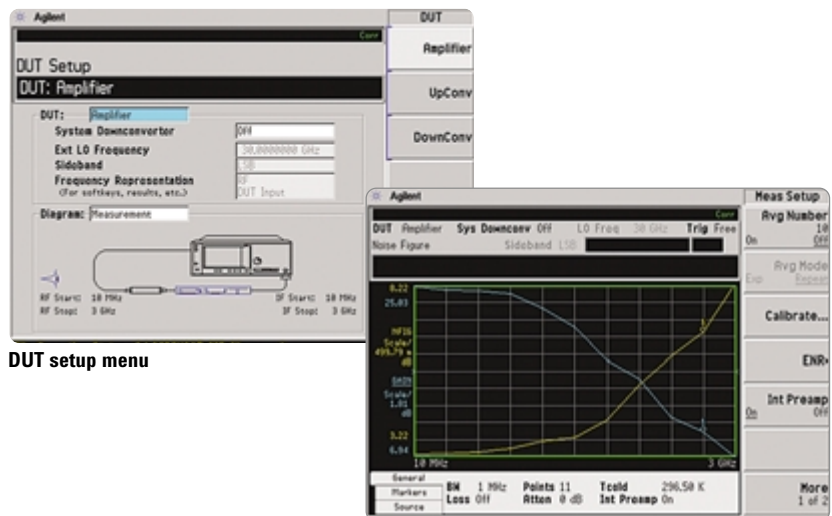

DUT setup menu

Noise figure and gain measurement

## Modulation Analysis

The wireless communications industry has stringent requirements on standards compliance. Agilent provides measurement personalities that simplify standards testing with one-button format-based measurements. Since this is the fourth generation of cellular communications personalities in our instruments, it has given us the opportunity to incorporate customer feedback to include feature, performance, and usability enhancements.

- offers the most complete standards-based modulation analysis available in a spectrum analyzer today
- supports both base station and mobile device testing
- complex algorithms executed with a single button press
- provides easy to read pass/fail indicators with operator independent results

### Digital demodulation hardware (Option B7J)

This option is required for all the cellular communications measurement personalities. It supplies a 1-dB electronic step attenuator for automatic optimization of speed and dynamic range and the basic measurement personality that provides spectrum and waveform analysis and I/Q pairs (10 MHz, 3 dB bandwidth) over GPIB or LAN.

### Flexible modulation analysis with Agilent 89601A vector signal analysis software

Embrace the power of flexible modulation analysis by linking the PSA to the 89601A vector signal analysis software. For frequencies up to 50 GHz, the PSA can serve as a front-end receiver for use with the 89601A. This software provides flexible tools for demodulating and analyzing even the most advanced digital formats whether or not they are defined by an established standard. Features include variable block size signal acquisition with user-selectable pulse search and synch words and a user-controllable adaptive equalizer.

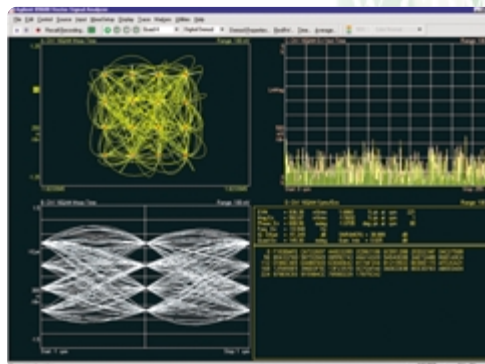

Agilent 89601A vector signal analysis software

# Cellular Communications Measurement Personalities

## NADC and PDC (Option BAE)

Both the North American Digital Cellular (NADC) and Personal Digital Cellular (PDC) measurement personalities are included in this option. The NADC measurements are structured according to the IS-136 TDMA standard. Measurements included in this option are

- adjacent channel power (ACP)
- error vector magnitude (EVM)
- occupied bandwidth (for PDC)

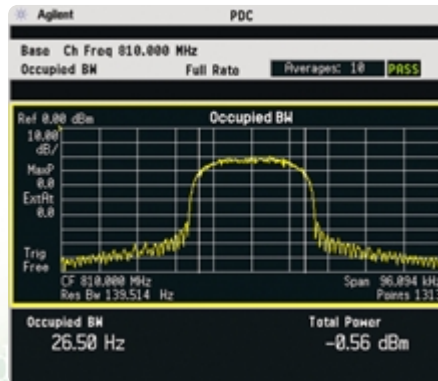

PDC occupied bandwidth

## cdmaOne (Option BAC)

Built on Agilent's pioneering efforts in CDMA measurement techniques, this personality provides quick and easy measurement setups for the TIA/EIA/IS-95 standards.

- modulation accuracy (rho)
- code domain analysis
- channel power
- adjacent channel power ratio (ACPR)
- close-in spurious

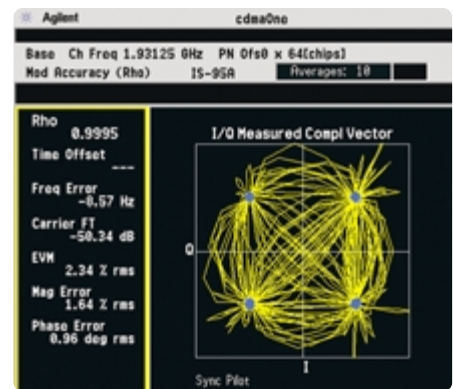

cdmaOne modulation accuracy

## GSM with EDGE (Option 202)

This option includes both Global System for Mobile Communications (GSM) and Enhanced Data Rates for GSM Evolution (EDGE) measurements. The following measurements are quick, easy to make, and standards-based:

- transmit power
- power versus time (PvT)
- phase and frequency error
- EDGE EVM
- output RF spectrum (ORFS)
- transmitter band spurious

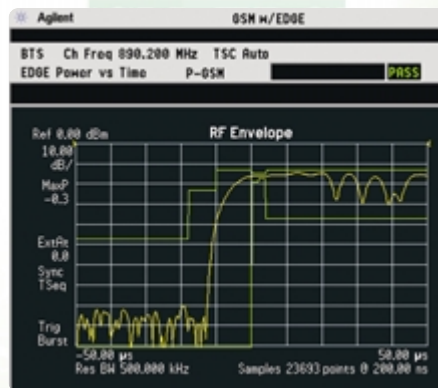

EDGE power versus time

## W-CDMA (Option BAF)

The complexity of W-CDMA demands the flexibility and depth of demodulation capability provided by this personality. Perform the following measurements on the HPSK uplink or downlink QPSK signals:

- code domain analysis
- QPSK EVM
- modulation accuracy (composite rho and EVM)
- channel power
- adjacent channel power leakage ratio (ACLR)
- intermodulation distortion
- multicarrier power
- spectrum emission mask
- occupied bandwidth
- CCDF

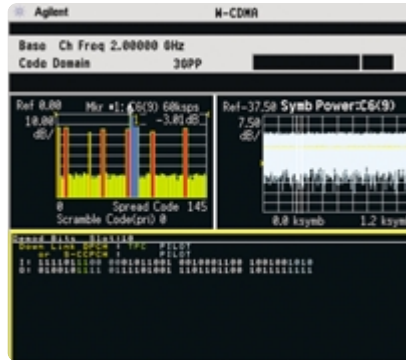

W-CDMA codedomain analysis

## cdma2000 (Option B78)

The cdma2000 measurement personality offers the logical upgrade path from IS-95 to IS-2000 testing. Measurements support the forward and reverse links.

- code domain analysis
- QPSK EVM
- modulation accuracy (composite rho and EVM)
- channel power
- adjacent channel power ratio
- intermodulation distortion
- spectrum emission mask
- occupied bandwidth
- CCDF



cdma2000 CCDF

## 1xEV-DO (Option 204)

The evolution to cdma2000 with 1xEV-DO introduces unique measurement capability. The following measurements are based on TIA/EIA/IS-2000.2 standards and are available for the forward and reverse link signals:

- code domain power
- modulation accuracy (composite rho)
- QPSK EVM
- PvT
- channel power
- intermodulation distortion
- spurious emissions and ACP
- occupied bandwidth
- CCDF



1xEV-DO modulation accuracy

## Practical Solutions

### Design efficiently and with confidence

To promote productivity in research and development, test and measurement tools must be flexible, thorough, and easy to use. Troubleshooting and design verification can be expedited and simplified with the PSA Series spectrum analyzers. With this one tool, it is easy to optimize setups for unique spectrum measurements, to customize advanced power measurements for modulated signals, and to dive down to the bit level using the digital demodulation personalities.

Essential to design verification is having confidence in measurement results. Understanding the importance of this, Agilent makes measurement integrity its highest priority. We provide guaranteed technical specifications to a set performance level on which you can depend.

### Increase and maintain manufacturing throughput

From high-volume automated testing of cellular base stations to manually tuning oscillators, the PSA Series optimizes manufacturing throughput on many levels.

*Increased throughput* – Fast sweeps and update rates reduce automated test times. Manual tests are accelerated by one-button setups and fewer required button presses per measurement. The PSA Series shifts easily between measurement personalities, minimizing changeover time and accelerating troubleshooting.

*Improved yields* – Excellent specifications reduce measurement uncertainty to allow for narrower test margins and improved yields. Sophisticated algorithms constantly monitor analyzer conditions and determine when internal background alignment is required.

*One analyzer, many solutions* – Using only 177 mm (7 in) of rack space, the PSA Series is packed with features. Superior accuracy and linearity may eliminate the need for a power meter. Cellular communications measurement personalities give it digital demodulation capability. The phase noise personality transforms it to a phase noise tester. The feature list is long and will continue to grow.

### Performance verification and adjustment software for instrument calibration

This software allows fast and accurate testing of PSA spectrum analyzers and provides ANSI Z540 compliant test reports. It runs on a PC platform running Windows® 95/98 or NT 4.0 and uses a standard calibration platform to help minimize calibration run time and operator involvement.



The PSA Series simplifies multicarrier power amplifier (MCPA) testing with in-channel, adjacent channel, and out-of-band measurements in one analyzer.

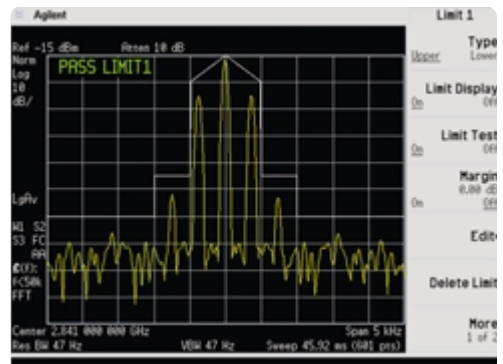

Customize limit lines for pass/fail testing.



## Connect

The PSA Series has built-in capability to network with PCs, printers, and software programs. Standard connectivity features include

- *VXIplug&play* drivers for Agilent VEE, National Instrument's LabView, and LabWindows to develop measurement routines, create new measurements, and collect results
- IntuiLink software for easy transfer of measurement results into Microsoft® Excel and Word
- floppy drive to store display screens in bitmap (.gif) format or to save trace data as a comma separated variable (.csv) file to export to spread sheets or Agilent Advanced Design System (ADS) design software
- GPIB and 10 baseT LAN for automated control and remote operation
- SCPI programmable
- code compatibility with the HP 8566B/8568B spectrum analyzers (Option 266)
- parallel port for printing
- BenchLink Web Remote, Agilent's web-based remote control software (Option 230), used to control analyzer functions, record and evaluate data, and view signals in real time, remotely anywhere in the world over the Web.
- Agilent's Connectivity Suites and products will enable you to make fast, easy instrument connections and create test programs based on the power of Microsoft Visual Studio/.NET.

For more information, please visit

[www.agilent.com/find/connectivity](http://www.agilent.com/find/connectivity)



## Service and Support

The performance and flexibility of the PSA Series spectrum analyzer is only a small part of what is available from Agilent. In a constantly changing environment, Agilent's ability to understand your business needs and quickly provide the latest end-to-end service and support solutions gives the certainty and confidence necessary to accelerate the development and deployment of winning technologies.

### Support solutions

Use Agilent's support solutions to get more from the PSA, as well as other test equipment, by increasing productivity and maximizing uptime. Our programs are designed with flexibility and can be tailored to meet your needs, including costs and response times.

**Repair services** ensure that the instrument is up and running as quickly as possible. The PSA comes with a 3-year return-to-Agilent warranty. Additional repair options are available at the time of purchase.

**Calibration services** guarantee measurement confidence in PSA. Choose return-to-Agilent or on-site service and order the service as needed or on a regularly scheduled basis.

**Volume On-site Calibration (VOSCAL) service** minimizes instrument downtime and associated costs by delivering quality calibration on-site without interfering with output schedules. VOSCAL is a fully operational, high-quality mobile calibration laboratory complete with high-specification systems and automation.

**System uptime services** provide Agilent's global resources and expertise to help prevent system failures and develop solutions to problems fast. Our system up-time teams are comprised of our best service specialists to keep systems up and running.

**Equipment management services** assist in managing test and measurement assets. Agilent's global equipment management solution helps maximize the utilization and reduce the ownership cost of test equipment.

For more information on Agilent support solutions visit:

[www.agilent.com/find/tm\\_services](http://www.agilent.com/find/tm_services)

### Knowledge services

Our goal at Agilent is to provide the key resources that will help you build the comprehensive solutions to stay competitive. Agilent's knowledge services are the best in the business and encompass a wide range of solutions designed with your goals in mind.

**Technical consulting** provides the required technical expertise to complete and implement specific test strategies.

**Process consulting** helps to integrate new R&D or manufacturing test processes and technology into your current environment.

**Enterprise business consulting** provides business-planning services focused on enterprise-wide test issues.

**Training and education** gives access to our depth of product expertise and helps keep you abreast of emerging technologies. Encompassing technology training, product training, measurement fundamentals and applications training, our classes can be delivered on-site or at an Agilent Training Center.

For more information on Agilent education and training visit:

[www.agilent.com/find/education](http://www.agilent.com/find/education)

## Key Specifications<sup>1</sup>

### E4443A/E4445A/E4440A/E4446A/E4448A

<b>Frequency range</b>	3 Hz to 6.7/13.2/26.5/44/50 GHz
<b>Speed</b>	
Sweep time, span $\geq$ 10 Hz	1 ms to 2000 s
Sweep time span = 0 Hz	1 $\mu$ s to 6000 s
Local measurement update rate	$\geq$ 50 measurements/sec
Remote measurement update rate	$\geq$ 45 measurements/sec
<b>Resolution</b>	
Resolution bandwidth range, swept and FFT	1 Hz to 3 MHz (10% steps), 4, 5, 8 MHz
Variable sweep (trace) point range	101 to 8192
Phase noise at 1 GHz	
10 kHz offset	-114 dBc/Hz (-117 dBc/Hz, typical)
1 MHz offset	-144 dBc/Hz (-148 dBc/Hz, nominal)
10 MHz offset	-151 dBc/Hz (-157 dBc/Hz, nominal)
<b>Dynamic range</b>	
Displayed average noise level (DANL)	
10 MHz to 3 GHz	-153 dBm (-152 dBm <sup>2</sup> )
3 GHz to 20 GHz	-147 dBm (-145 dBm <sup>2</sup> )
20 GHz to 26.5 GHz	-143 dBm (-140 dBm <sup>2</sup> )
26.5 GHz to 44 GHz	N.A. (-129 dBm <sup>2</sup> )
44 GHz to 50 GHz	N.A. (-127 dBm <sup>2</sup> )
Preamplifier (DANL), 10 MHz to 3 GHz	-166 dBm (-164 dBm <sup>2</sup> )
1 dB gain compression, 200 MHz to 3 GHz	+3 dBm (+7 dBm nominal)
Input attenuator range	0 to 70 dB in 2 dB steps
TOI, 1.7 GHz to 3.0 GHz	+17 dBm (+19 dBm typical) [+18 dBm (+21 dBm typical)] <sup>2</sup>
ACPR, W-CDMA (5 MHz offset)	
Dynamic range	-74.5 dB (typical)
with noise correction	-81 dB (typical)
<b>Accuracy</b>	
Absolute amplitude accuracy	$\pm$ (0.24 dB + frequency response)
95% confidence, 3 Hz to 3 GHz	$\pm$ 0.24 dB
Frequency response, 3 Hz to 3 GHz	$\pm$ 0.38 dB ( $\pm$ 0.15 dB typical)
Frequency accuracy (1 GHz)	$\pm$ 100 Hz
ACPR, W-CDMA accuracy (5 MHz offset)	
Mobile station	$\pm$ 0.12 dB
Base station	$\pm$ 0.22 dB

1. See PSA Series spectrum analyzers data sheet for more specification details (literature number 5980-1284E).

2. Specifications for E4446A and E4448A.

3. Options not available in all countries.

## Ordering Information

### PSA Series spectrum analyzer

E4443A	3 Hz to 6.7 GHz
E4445A	3 Hz to 13.2 GHz
E4440A	3 Hz to 26.5 GHz
E4446A	3 Hz to 44 GHz
E4448A	3 Hz to 50 GHz

### Options

To add options to a product, use the following ordering scheme:

Model	E444xA (x = 0, 3, 5, 6 or 8)
Example options	E4440A-B7J E4448A-1DS

### Digital demodulation hardware

E444xA-B7J	Digital demodulation hardware (required for digital demodulation measurement personalities)
------------	---

### Digital demodulation measurements

E444xA-BAF	W-CDMA measurement personality
E444xA-202	GSM w/ EDGE measurement personality
E444xA-B78	cdma2000 measurement personality
E444xA-204	1xEV-DO measurement personality
E444xA-BAC	cdmaOne measurement personality
E444xA-BAE	NADC, PCD measurement personality

### General purpose measurements

E444xA-226	Phase noise measurement personality
E444xA-219	Noise figure measurement personality

### Amplifiers

E444xA-1DS	100 kHz to 3 GHz built-in preamplifier
------------	--

### Inputs and outputs

E4440A-BAB	Replaces type-N input connector with APC 3.5 connector
------------	--

### Connectivity software

E444xA-230	BenchLink Web Remote Control Software
------------	---------------------------------------

### Code compatibility

E444xA-266	HP 8566B/8568B code compatibility measurement personality
------------	---

### Accessories

E444xA-1CM	Rack mount kit
E444xA-1CN	Front handle kit
E444xA-1CP	Rack mount with handles
E444xA-1CR	Rack slide kit
E444xA-045	Millimeter wave accessory kit
E444xA-0B1	Extra manual set including CD ROM

### Warranty and service

For warranty and service of 5 years, please order 60 months of R-51B (quantity = 60). Standard warranty is 36 months.

R-51B	Return-to-Agilent warranty and service plan
-------	---

### Calibration<sup>3</sup>

For 3 years, order 36 months of the appropriate calibration plan shown below. For 5 years, specify 60 months.

R-50C-001	Standard calibration
R-50C-002	Standards compliant calibration

E444xA-0BW	Service manual and calibration software
E444xA-UK6	Commercial calibration certificate with test data

# Product Literature

- *PSA Series*, data sheet, literature number 5980-1284E
- *Self-Guided Demonstration for Spectrum Analysis*, product note, literature number 5988-0735EN
- *Phase Noise Measurement Personality*, technical overview, literature number 5988-3698EN
- *Noise Figure Measurement Personality*, technical overview, number 5988-7884EN
- *W-CDMA Measurement Personality*, technical overview, literature number 5988-2388EN
- *GSM with EDGE Measurement Personality*, technical overview, literature number 5988-2389EN
- *cdma2000 Measurement Personality*, technical overview, literature number 5988-3694EN
- *1xEV-DO Measurement Personality*, technical overview, literature number 5988-4828EN
- *cdmaOne Measurement Personality*, technical overview, literature number 5988-3695EN
- *NADC/PDC Measurement Personality*, technical overview, literature number 5988-3697EN
- *Optimizing Dynamic Range for Distortion Measurements*, product note, literature number 5980-3079EN
- *PSA Series Amplitude Accuracy*, product note, literature number 5980-3080EN
- *PSA Series Swept and FFT Analysis*, product note, literature number 5980-3081EN
- *PSA Series Measurement Innovations and Benefits*, product note, literature number 5980-3082EN
- *8 Hints for Millimeter Wave Spectrum Measurements*, application note, literature number 5988-5680EN
- *PSA Series Spectrum Analyzers, Option H70, 70 MHz IF Output*, product overview, literature number 5988-5261EN
- *PSA Series Spectrum Analyzer Performance Guide Using 89601A Vector Signal Analysis Software*, product note, literature number 5988-5015EN
- *89600 Series + PSA, 802.11a and HiperLAN2 OFDM Measurements*, product note, literature number 5988-4094EN
- *Selecting the Right Signal Analyzer for Your Needs*, selection guide, literature number 5968-3413E
- *HP 8566B/68B Programming Code Compatibility for PSA and ESA-E Series Spectrum Analyzers*, product overview, literature number 5988-5808EN
- *BenchLink Web Remote Control Software*, product overview, literature number 5988-2610EN
- *IntuiLink Software*, Data Sheet, Literature Number 5980-3115EN

For more information on the PSA Series or to view the above-listed literature, please visit:

[www.agilent.com/find/psa](http://www.agilent.com/find/psa)

Microsoft is a U.S. registered trademark of Microsoft Corp.  
BLUETOOTH is a trademark owned by Bluetooth SIG, Inc., U.S.A. and licensed to Agilent Technologies.



## Agilent Email Updates

[www.agilent.com/find/emailupdates](http://www.agilent.com/find/emailupdates)

Get the latest on the products and information you select.

## Agilent Technologies' Test and Measurement Support, Services, and Assistance

Agilent Technologies aims to maximize the value you receive, while minimizing your risk and problems. We strive to ensure that you get the test and measurement capabilities you paid for and obtain the support you need. Our extensive support resources and services can help you choose the right Agilent products for your applications and apply them successfully. Every instrument and system we sell has a global warranty. Support is available for at least five years beyond the production life of the product. Two concepts underlie Agilent's overall support policy: "Our Promise" and "Your Advantage."

### Our Promise

Our Promise means your Agilent test and measurement equipment will meet its advertised performance and functionality. When you are choosing new equipment, we will help you with product information, including realistic performance specifications and practical recommendations from experienced test engineers. When you use Agilent equipment, we can verify that it works properly, help with product operation, and provide basic measurement assistance for the use of specified capabilities, at no extra cost upon request. Many self-help tools are available.

### Your Advantage

Your Advantage means that Agilent offers a wide range of additional expert test and measurement services, which you can purchase according to your unique technical and business needs. Solve problems efficiently and gain a competitive edge by contracting with us for calibration, extra-cost upgrades, out-of-warranty repairs, and onsite education and training, as well as design, system integration, project management, and other professional engineering services. Experienced Agilent engineers and technicians worldwide can help you maximize your productivity, optimize the return on investment of your Agilent instruments and systems, and obtain dependable measurement accuracy for the life of those products.

### Agilent T&M Software and Connectivity

Agilent's Test and Measurement software and connectivity products, solutions and developer network allows you to take time out of connecting your instruments to your computer with tools based on PC standards, so you can focus on your tasks, not on your connections. Visit

[www.agilent.com/find/connectivity](http://www.agilent.com/find/connectivity) for more information.

**By internet, phone, or fax, get assistance with all your test & measurement needs**

#### Phone or Fax

**United States:**  
(tel) 800 452 4844

**Canada:**  
(tel) 877 894 4414  
(fax) 905 282 6495

**China:**  
(tel) 800 810 0189  
(fax) 800 820 2816

**Europe:**  
(tel) (31 20) 547 2323  
(fax) (31 20) 547 2390

**Japan:**  
(tel) (81) 426 56 7832  
(fax) (81) 426 56 7840

#### Korea:

(tel) (82 2) 2004 5004  
(fax) (82 2) 2004 5115

**Latin America:**  
(tel) (305) 269 7500  
(fax) (305) 269 7599

**Taiwan:**  
(tel) 0800 047 866  
(fax) 0800 286 331

**Other Asia Pacific Countries:**  
(tel) (65) 6375 8100  
(fax) (65) 6836 0252

Email:  
tm\_asia@agilent.com

#### Online Assistance:

[www.agilent.com/find/assist](http://www.agilent.com/find/assist)

Product specifications and descriptions in this document subject to change without notice.

© Agilent Technologies, Inc., 2001, 2002  
Printed in USA, December 13, 2002  
5980-1283E



Agilent Technologies